

# CITROEN D - FRONT AXLE

## SUGGESTED MODIFICATION FOR LUBRICATION OF SUSPENSION ARM BEARINGS

These bearings tend to become 'notchy' and stiff due to lack of lubrication. Oil will stop this happening, or at least, prevent it from getting any worse.

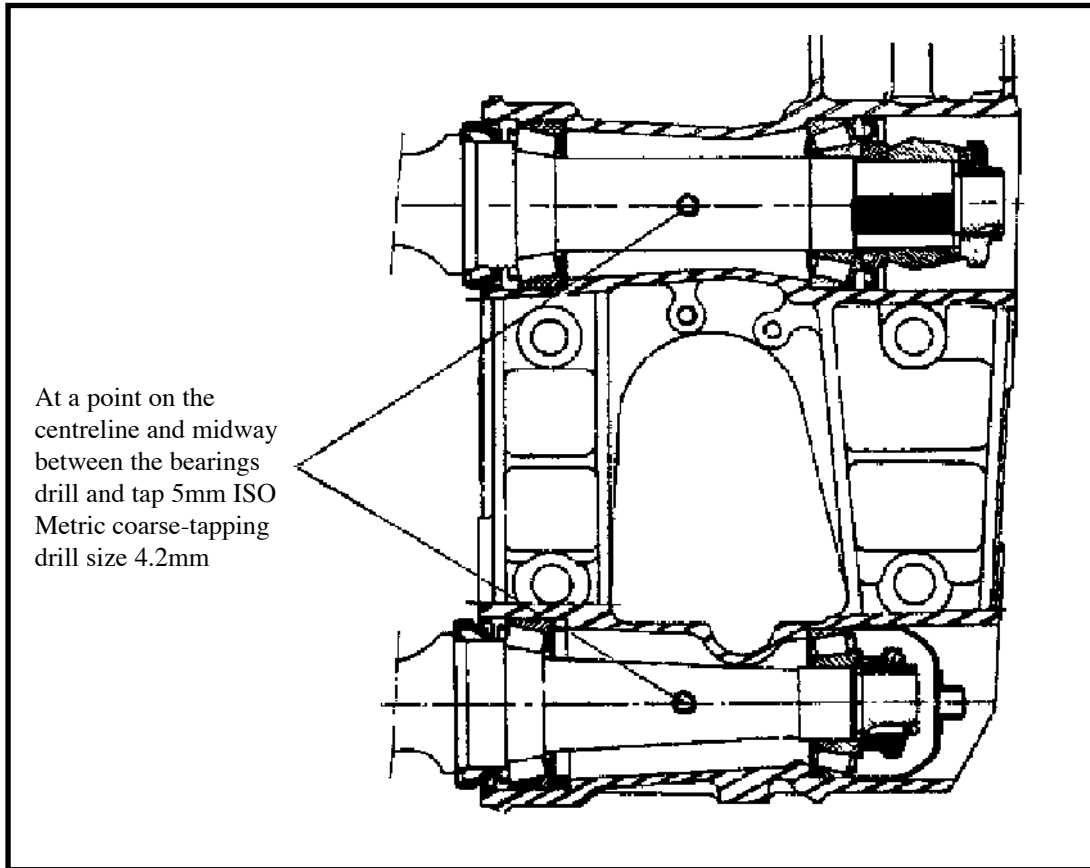

Hold a vacuum cleaner spout adjacent to drill and tap in use. Grease on the drill and tap will help to hold the swarf. If a little swarf enters the housing don't worry too much; aluminium alloy is soft and will not harm the bearings.

Fill the housings with SAE 50 oil, *not grease*, to the level of the drilled holes.

Cut a standard Citroen 5mm set screw to a length of about 8mm: coat the thread with sealant and screw it into the tapped hole as a plug.

**NEVER FIT A GREASE NIPPLE.** Pumping grease into the housings can blow the seals and allow water to enter the bearings.